



Как заказать

КНВЗК - G1/2 - L - 1 1 1 2 - 04
 [1] [2] [3] [4] [5] [6] [7] [8]

- [1] Модель: КНВЗК–Квадратный корпус DN04-50
- [2] Размер присоединительной резьбы: например G1/2
- [3] Тип крана по распределению потока L или T тип
- [4] Материал корпуса и присоединительных штуцеров
 1– Углеродистая сталь
 4– Нержавеющая сталь 304
- [5] Материал шара и стержня: 1–Углеродистая сталь;
 4–Нержавеющая сталь 304
- [6] Материал уплотнения шара: 1–POM; 4–PTFE; 5–PEEK
- [7] Материал уплотнения стержня и присоединительных штуцеров
 2– NBR(Buna); 4–FPM(Viton); 6–EPDM
- [8] Тип ручки: 04–Ручка под углом из оцинкованной стали
 05–Стальная ручка прямая
 06–Стальная ручка под углом

Схема

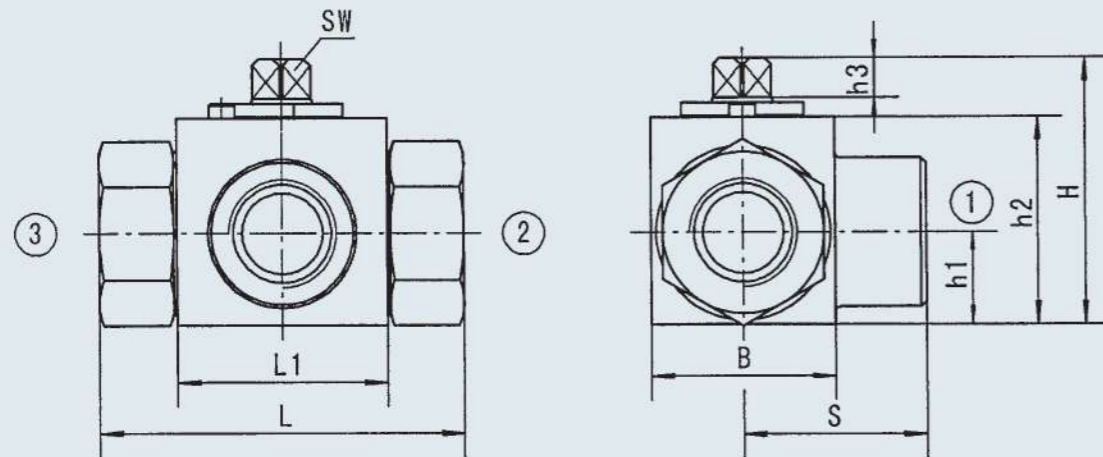
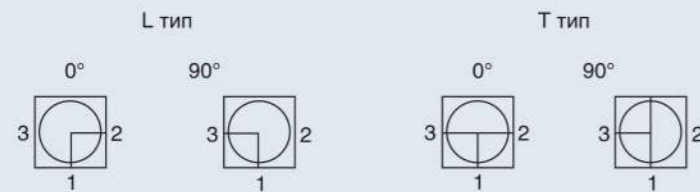

ISO 228

Модель	DN	PN	LW	d1	i	L	L1	B	H	h1	h2	h3	SW	S
КНВЗК–G1/8	4	315	6	G1/8	10	69	37	28	44.5	13	32	8	9	35
КНВЗК –G1/4	6	315	6	G1/4	14	69	37	28	44.5	13	32	8	9	35
КНВЗК –G3/8	10	315	10	G3/8	14	72	42	32	52.5	17	40	8	9	36
КНВЗК –G1/2 –SW9	13	315	13	G1/2	16	83	48	35	52.5	17	40	8	9	40
КНВЗК –G1/2 –SW12	16	315	15	G1/2	16	83	47	38	63.5	19	46	11	12	42
КНВЗК –G3/4	20	315	20	G3/4	18	95	60	48	75	24	57	12	14	49
КНВЗК –G1	25	315	25	G1	20.5	113	65	57	82	28.5	64	12	14	56.5
КНВЗК –G1¼	25/32	315	25	G1¼	22	120	65	60	82	28.5	64	12	14	60
КНВЗК –G1¼	32	315	30	G1¼	22	110	84	75	104.5	37.5	84	14	17	55
КНВЗК –G1½	40	315	38	G1½	24	130	91	85	115.5	42.5	95	14	17	65
КНВЗК –G2	50	315	48	G2	26	140	100	105	133	52.5	112.5	14	17	70

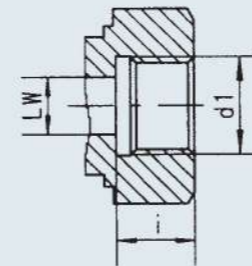

DIN 2353

Диапазон давления присоединения труб

Модель	DN	PN	LW	RA	d1	i	L	L1	B	H	h1	h2	h3	SW1	S
КНВЗК –06LR	4	315	4	6	M12×1.5	10	67	37	28	44.5	13	32	8	9	34.5
КНВЗК –08LR	6	315	6	8	M14×1.5	10	67	37	28	44.5	13	32	8	9	34.5
КНВЗК –10LR	8	315	8	10	M16×1.5	11	74	42	32	52.5	17	40	8	9	37
КНВЗК –12LR	10	315	10	12	M18×1.5	11	74	42	32	52.5	17	40	8	9	37
КНВЗК –15LR–SW9	13	315	13	15	M22×1.5	12	82	48	35	52.5	17	40	8	9	40
КНВЗК –15LR–SW12	13	315	13	15	M22×1.5	12	82	47	38	63.5	19	46	11	12	40
КНВЗК –18LR–SW9	13	315	13	18	M26×1.5	12	82	48	35	52.5	17	40	8	9	42
КНВЗК –18LR–SW12	16	315	15	18	M26×1.5	12	82	47	38	63.5	19	46	11	12	42
КНВЗК –22LR	20	315	19	22	M30×2	14	101	60	48	75	24	57	12	14	52
КНВЗК –28LR	25	315	25	28	M36×2	14	108	65	57	82	28.5	64	12	14	54
КНВЗК –35LR	25/32	315	25	35	M45×2	16	112	65	60	82	28.5	64	12	14	56

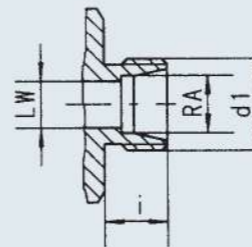

DIN 2353

Модель	DN	PN	LW	RA	d1	i	L	L1	B	H	h1	h2	h3	SW1	S
КНВЗК –08SR	4	315	5	8	M16×1.5	12	73	37	28	44.5	13	32	8	9	37
КНВЗК –10SR	6	315	6	10	M18×1.5	12	73	37	28	44.5	13	32	8	9	37
КНВЗК –12SR	8	315	8	12	M20×1.5	12	76	42	32	52.5	17	40	8	9	38
КНВЗК –14SR	10	315	10	14	M22×1.5	14	80	42	32	52.5	17	40	8	9	40
КНВЗК –16SR–SW9	13	315	13	16	M24×1.5	14	86	48	35	52.5	17	40	8	9	43.5
КНВЗК –16SR–SW12	13	315	13	16	M24×1.5	14	86	47	38	63.5	19	46	11	12	43.5
КНВЗК –20SR–SW9	13	315	13	20	M30×2	16	90	48	35	52.5	17	40	8	9	45.5
КНВЗК –20SR–SW12	16	315	15	20	M30×2	16	90	47	38	63.5	19	46	11	12	45.5
КНВЗК –25SR	20	315	20	25	M36×2	18	109	60	48	75	24	57	12	14	56
КНВЗК –30SR	25	315	25	30	M42×2	20	120	65	57	82	28.5	64	12	14	60
КНВЗК –38SR	25/32	315	25	38	M52×2	22	124	65	60	82	28.5	64	12	14	62

